

Features

- High efficiency up to 95%
- THD <20%
- Output current adjusted via DIP switch and fine-tuned via potentiometer
- CCT adjustable via DIP switch (optional)
- 2 versions selectable: 3-in-1 dimming & 3-in-1 dimming + 12V AUX output
- Dim to off without afterglow (optional and for HBA version only)
- Surge protection: L-N: 6kV & L/N-GND: 6kV
- All-round protections: over voltage protection and short circuit protection
- Flicker free



Application

- Highbay light

Descriptions

LF-HBA/HBC240 is a constant current LED driver featuring high efficiency, high PF and low THD. It has 2 selectable versions: 3-in-1 dimming & 3-in-1 dimming + 12V AUX output. There is a potentiometer and 2 DIP switches on the side of LED driver used for adjusting the output current (power) of LED drivers and CCT of luminaires.

Product Model

LF - HBA /C240



- 240: output power: 240W
- C: 3-in-1 dimming
- A: 3-in-1 dimming + 12V
- H: high voltage; B: for highbay light

■ Electrical Characteristics

Model		LF-HBA240			LF-HBC240		
Output	Adjustable Output Current (TYP@220Vdc)	Adjusted via DIP switch and fine-tuned via potentiometer (600-1100mA; default setting: 1000mA ±5%)					
		600mA	LOW	800mA	MID	1000mA	HIGH
	Changeable CCT (one LED+)	Adjustable via DIP switch (optional); two-channel output					
		Channel A		Channel A+B		Channel B	
	Output Voltage	180-260Vdc (LED)					
	Output Power	240W max. @120-347Vac					
	Start-up Time	120Vac <1S; 277Vac <0.5S; 347Vac <0.5S					
	Linear Adjustment Rate	±5% @full load					
	Load Adjustment Rate	±8% @full load					
Temperature Drift	±3% @240Vdc/1000mA Tc: 25~75°C						
Input	Input Voltage	120-347Vac					
	DC Input Voltage	141-400Vdc					
	Input Current	3.0A max.					
	PF	≥0.9/347Vac @full load					
	THD	≤20% @full load					
	Efficiency	MIN	91%/120Vac; 93.5%/277Vac; 93.5%/347Vac@240Vdc/1000mA				
		TYP	93%/120Vac; 95%/277Vac; 95%/347Vac@240Vdc/1000mA				
		MAX	/				
In-rush Current	<80A/350uS @120Vac; <120A/350uS @347Vac						
12V AUX Output (for HBA only)	Output Voltage	+12Vdc (11-14V)					
	Output Current	200mA max.					
	Dynamic Load	Please make sure that it matches the LED driver.					
	Ripple Voltage	≤1V					
Protection Characteristics	Surge	L-N: 6kV (2Ω), L/N-PE: 6kV (12Ω)					
	Open Circuit	Open-circuit voltage ≤310Vdc					
	Short Circuit	≤15W The LED driver will recover by itself and will not be damaged even in the state of short circuit for a long time.					
	Grounding Resistance	≤0.1Ω @25A/60S					
	Insulation Resistance	≥100MΩ @I/P-PE O/P-PE: 500Vdc/60S/25°C/50%RH					

■ Electrical Characteristics

Environment Descriptions	Operating Temperature	-40°C~+50°C (Tc<90°C)
	Operating Humidity	0~95%RH (no condensation)
	Storage Temperature/ Humidity	-40°C~+80°C (6 months in Class I environment); 0~95%RH (no condensation)
	Atmospheric Pressure	86~106kPa
Safety and EMC	Certifications	FCC, UL
	Withstanding Voltage	L-N/PG: 1.76kVac, <5mA, 60S; L-N/DIM: 1.76kVac, <5mA, 60S; DIM/PG: 500Vac, <5mA, 60S
	Safety Standards	UL: UL8750, CSA 250.13
	EMI	FCC: PART 15 CLASS B @120Vac FCC: PART 15 CLASS A @347Vac
	EMS	Complies with IEC61000-4-2, 3, 4, 5, 6, 8, 11, 12; IEC61547
	Ringing Wave	4kV
	ESD	Air 8kV, touch 4kV
Other Parameters	IP Rating	IP65
	RoHS	RoHS 2.0 (EU) 2015/863
	Warranty	5 years (Tc≤80°C)
	MTBF	>1000Khours@Telcordia SR-332 Issue4
Test Equipment	Digital power meter: CHROMA66202, oscilloscope: Tektronix DPO3014, DC electronic load: M9712B, LED board, constant temperature and humidity chamber; Everfine EMS61000-5B; Everfine EMS61000-4A, spectroanalyzer: KH3935, hi-pot tester: TH9201B, etc.	
Test Remark	If there are no special remarks, the above parameters are tested at the ambient temperature of 25°C, humidity of 50%, full load and input voltage of 230Vac.	

■ **Electrical Characteristics**

Additional Remarks	<ol style="list-style-type: none"> 1. It is recommended that user install over voltage protection, under voltage protection and surge protection devices in the power supply circuits of light fixtures to ensure electricity safety. 2. The PC cover, casing and end cap for assembling the LED driver in the light fixture must meet the fire rating of UL94-V0 or above. 3. The LED driver used in combination with the end device is one of the accessories of the whole light fixture, and the EMC of the whole light fixture is not only susceptible to the driver itself, but to the LED light fixture and the whole light fixture's wiring. Thus, the manufacturer of LED light fixture should re-confirm the EMC of the whole light fixture before the whole light fixture is finished. 4. It is suggested that user use a slotted screwdriver or a Philips to adjust the output current of LED driver in case that the potentiometer is damaged (the screwdriver should have good insulation at the head, body and handle, and the screwdriver with a 2mm head is recommended as well; what's more, please pay attention that the intensity of torque not exceed 500g.cm). 5. When using the LED driver, please pay attention that the total output power not exceed the maximum rated output power, otherwise the warranty service of LED driver would be failed. 6. When conducting withstanding voltage test on LED driver, please short-circuit the input wire L and N; the positive electrode and negative electrode of the output wire; the positive electrode and negative electrode of the dimming wire and AUX power supply. 7. Please fully inspect the withstanding voltage ability of LEDs and aluminum substrates and the value shall >2.5kVac.
---------------------------	--

■ **Qty & Parameters of Driver (the same model) a Circuit Breaker Configures**

Item	Peak Inrush Current (Ipeak)	Half-peak Inrush Time (Twidth)
Input voltage 120Vac	34.26A	85.6uS
Input voltage 230Vac	68A	314uS

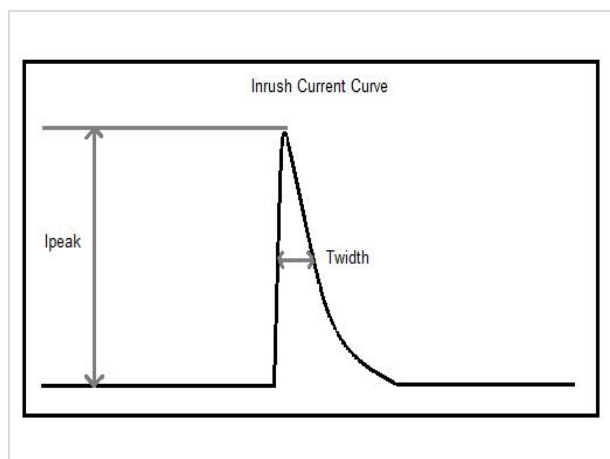

Qty of Driver a Circuit Breaker Configures (input voltage: 230Vac)		
Type	Rating	Qty of Driver
B	10A	4 pcs
	13A	5 pcs
	16A	6 pcs
	20A	7 pcs
	25A	9 pcs
C	10A	6 pcs
	13A	7 pcs
	16A	9 pcs
	20A	12 pcs
	25A	14 pcs

■ **Product Characteristic Curves**

PF Curve

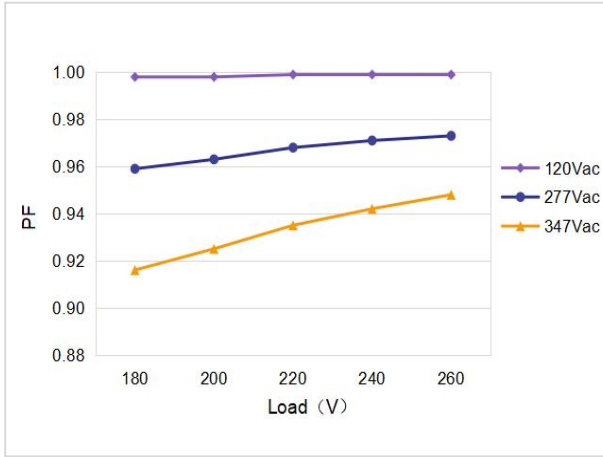

Efficiency Curve

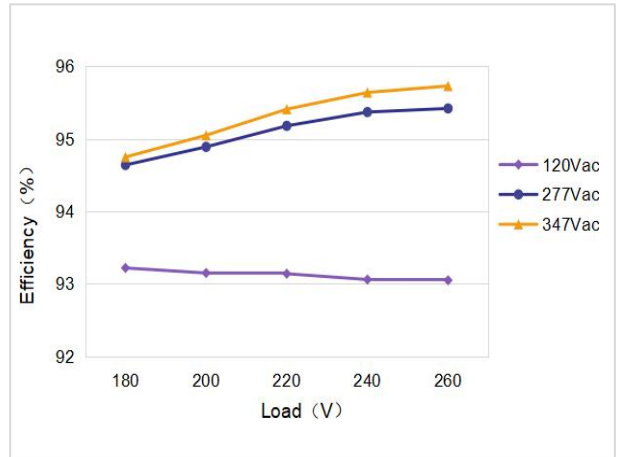

Load Derating Curve

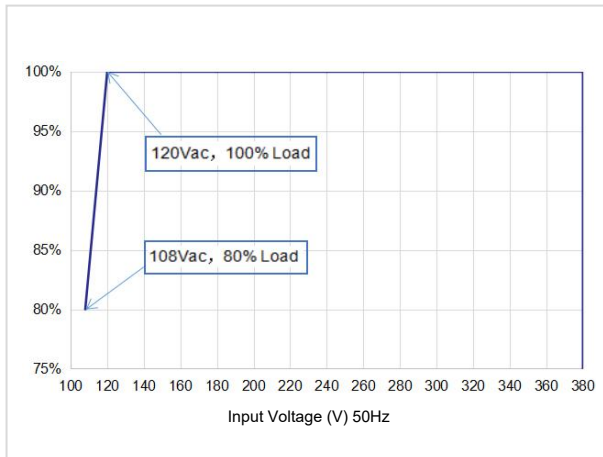

Power Curve

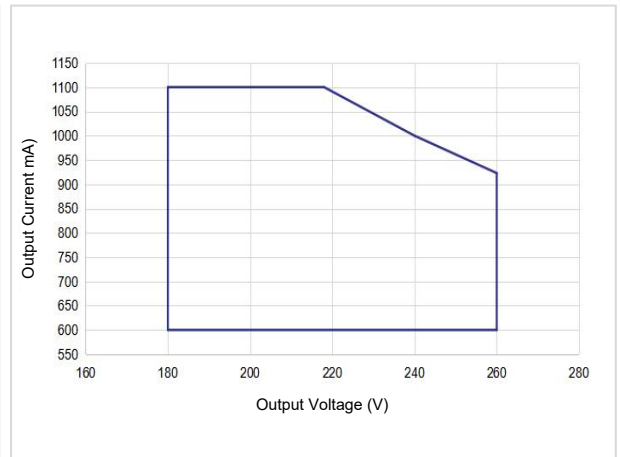

Lifetime Curve

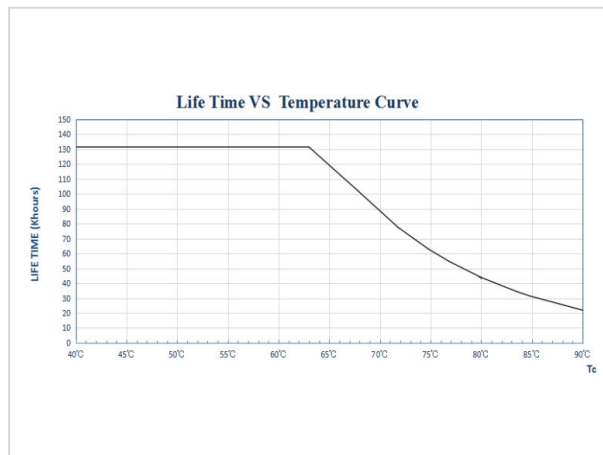

■ Dimming Operation Instructions

0-10V Dimming Operations

- Connect 0-10V signal to DIM terminal.
- In 0-10V dimming mode, when the input voltage is $0.8V \pm 0.15$, the light turns off; when it's $1.0V \pm 0.15$, the light turns on.
- Dimming depth: 10% (typical value)
- DIM+/- (without signal connected): 100% rated current output

Wiring Diagram of 0-10V Dimming

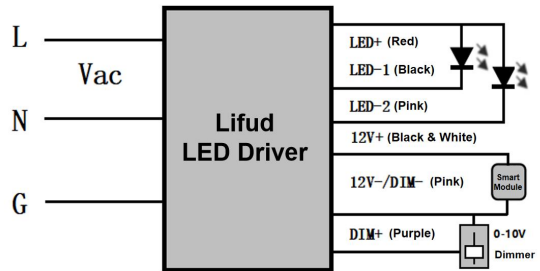

This diagram is for HBA series only;
HBC series has no 12V+.

Dimming Curve

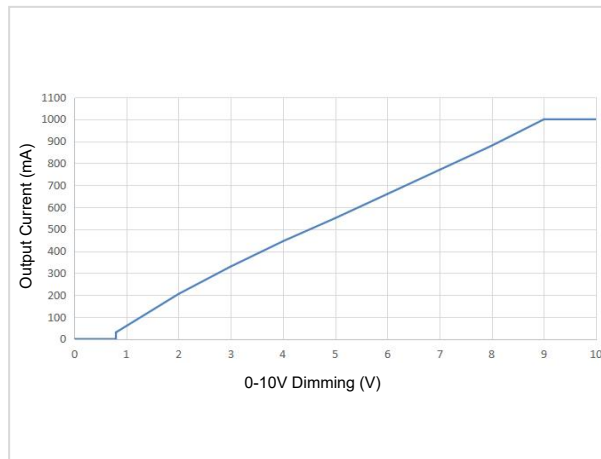

Input: 277Vac; output: 240Vdc/1000mA
(this data is measured by Lifud 0-10V dimmer and the chart is for reference only)

■ **Dimming Operation Instructions**

PWM Dimming Operations

- Connect PWM signal to the DIM terminal.
- Dimming depth: 10% (typical value)
- Compatible signal range: 1000-2000(Hz), amplitude: 9-10(V)
- DIM+/- (without signal connected): 100% rated current

Wiring Diagram of PWM Dimming

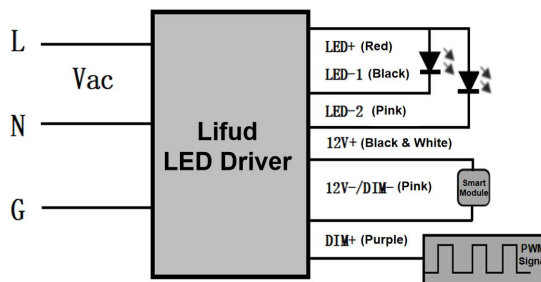

Dimming Curve

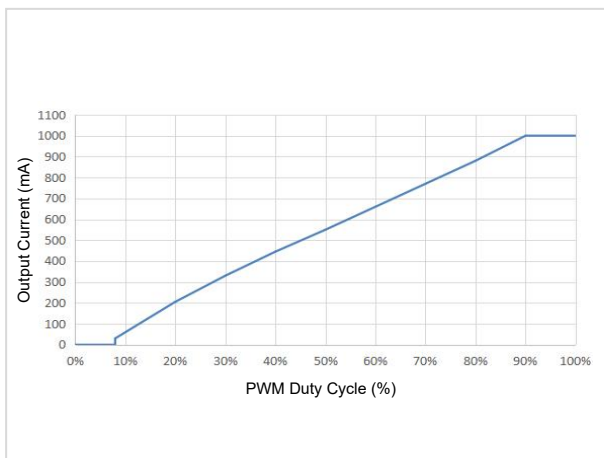

Input: 277Vac; output: 240Vdc/1000mA
 (this data is measured by Lifud PWM signal generator RIGOL and the chart is for reference only)

■ Dimming Operation Instructions

Rx Dimming Operations

- Connect Rx signal to the DIM terminal.
- Range: 0-100KΩ
- DIM+/- (without signal connected): 100% rated current

Wiring Diagram of Rx Dimming

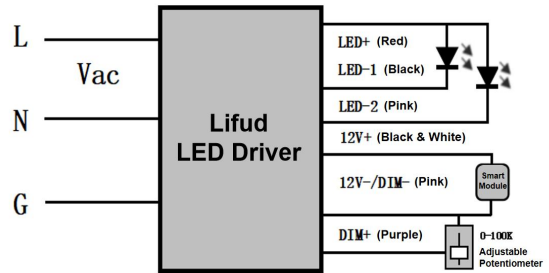

This diagram is for HBA series only;
HBC series has no 12V+.

Dimming Curve

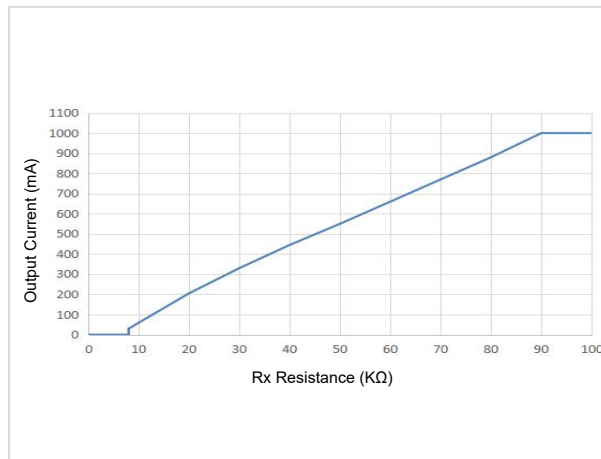

Input: 277Vac; output: 240Vdc/1000mA
(this data is measured by resistance dimmer and the chart is for reference only)

■ **Dimming Operation Instructions**

Dim-to-off “Without Afterglow” Operation

The dim-to-off without afterglow version of HBA series is optional. If the other with afterglow versions need to be dimmed to off without afterglow, please refer to the following operation: when the dimming signal is 0V, the LED driver has no output, but there exists junction capacitance between the aluminum substrate’s copper foil and the grounding wire, which will make the LED beads glow slightly. Thus, it is necessary to respectively attach a resistor to every node of LEDs in parallel, and the resistance should match for the parameters of aluminum substrate and LEDs. (reference resistance: 3-5KΩ/size: 1206)

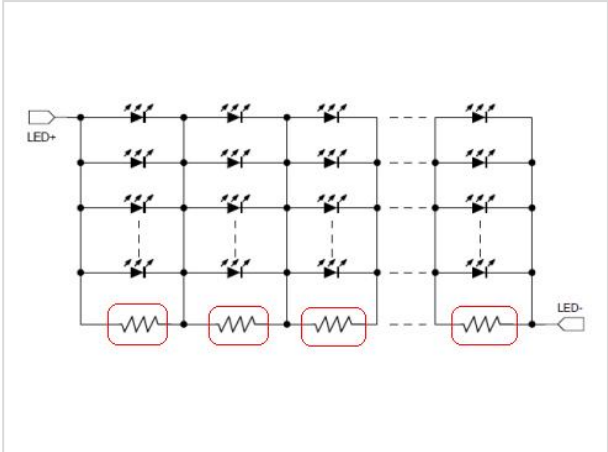

■ **Structure & Dimensions (unit: mm)**

Wire Specifications

Type	Input Wire	Output Wire 1	Output Wire 2 CCT Changeable via DIP Switch (optional)	Dimming Wire & AUX Output Wire
US-standard	3*18AWG Φ 9.3 \pm 1mm	2*18AWG Φ 7.7 \pm 1mm	3*18AWG Φ 7.7 \pm 1mm	HBA: 3*22AWG Φ 5.0 \pm 1mm HBC: 2*22AWG Φ 4.5 \pm 1mm
Color	AC-L Black; AC-N White; PE Green	LED+ Red; LED- Black	LED+ Red; LED-1 Black; LED-2 Pink	DIM+ Purple; DIM- Pink; +12V Black & White
Length	300 \pm 10mm (L1)	200 \pm 8mm (L2)	200 \pm 8mm (L2)	280 \pm 8mm (L3)
				200 \pm 8mm (L4)
Peeled	40 \pm 4mm (X1)	35 \pm 4mm (X2)	35 \pm 4mm (X2)	40 \pm 4mm (X3/X4)
Tinned	10 \pm 1.5mm (Y1)	10 \pm 1.5mm (Y2)	10 \pm 1.5mm (Y2)	10 \pm 1.5mm (Y3/Y4)

■ **Structure & Dimensions (unit: mm)**

Product Dimensions & Structure Diagrams

Description	Symbol	Unit (mm)
Casing Diameter	A	$\Phi 127.5 \pm 0.5$
Diameter of Fixed Screw Hole	4-B	$\Phi 6.3 \pm 0.2$
Diameter of Assembly Hole	W	113 ± 0.5
Ring's Hole	Z	M10*1.5
Casing Height	H	58.6 ± 0.5

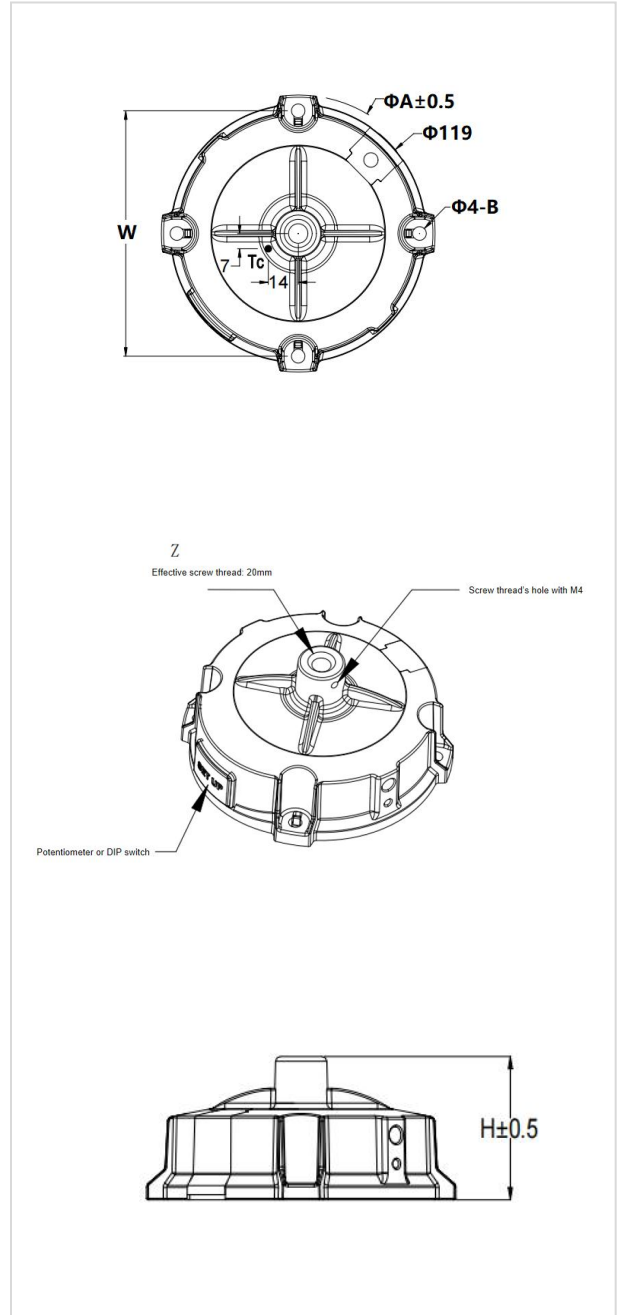
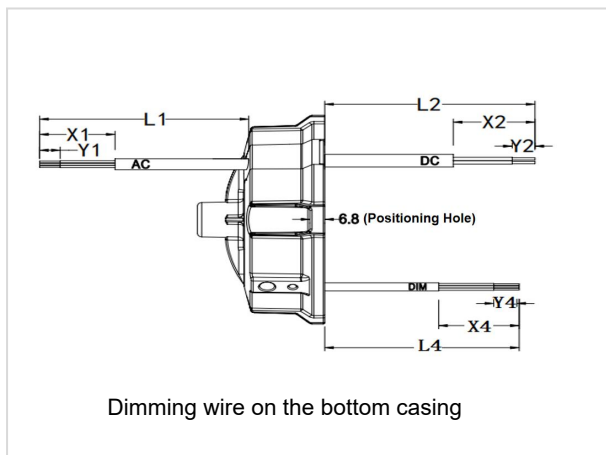
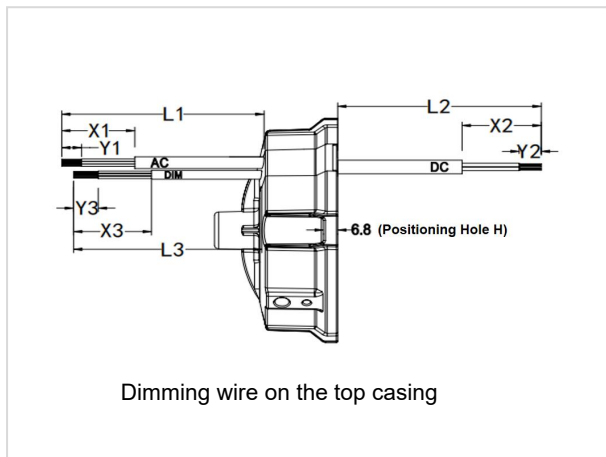

■ **Packaging Specifications**

Model	LF-HBA/HBC240
Carton Size	570*380*160 mm (L*W*H)
Quantity	15 pcs/layer; 1 layer/ctn; 15 pcs/ctn
Weight	0.65±0.1 kg/pc; 11.7±1.2 kg/ctn

■ **Transportation and Storage**

1. Transportation

- Suitable transportation means: vehicles, boats and aeroplanes.
- In transit, it is necessary to prepare awnings for rain or sun protection. Moreover, please keep civilized loading and unloading to prevent the vibration or impact of LED driver as much as possible.

2. Storage

- The storage of LED driver shall conform to the standard of Class I environment. When using LED drivers which have been stored for more than 6 months, please re-test them firstly. Do not use them unless they are tested to be qualified.

Cautions

- Please use Lifud LED driver according to its parameters in the specification, otherwise the LED driver may malfunction.
- Using any incompatible light fixtures or those that have not been certified may cause fire, explosion or other risks.
- Man-made damage is beyond the scope of Lifud warranty service.

Remark: Lifud Tecnology Co., Ltd. reserves the right to interpret any contents of this specification.