

I. Description

Designed and produced by Lifud Technology Co., Ltd., LF-GSP012YH is an LED emergency driver which can work with external LED driver (output DC 25-48V, constant current source less than 2A DC), together they can power the same LED load and satisfy the lighting requirements in normal and emergency situation. When there's power failure, this emergency driver, LF-GSP012YH, switches to emergency mode and provides at least 1.5 hour lighting. This product consists of a circuit for battery charging and a circuit for switching emergency voltage. The narrow shape of the driver makes sure that it fits narrow space inside the light fixture.

The output voltage range of LF-GSP012YH is 25V- 48V, and the emergency output power is constant. The emergency power can be selected as 5W, 7W, 10W or 12W via the DIP switch. The unique software algorithm automatically identifies the voltage of the LED load and the selected emergency power. It effectively avoids the reduction of illumination power caused by the decrease of LED load voltage after long-term use of LED constant current driver.

The LF-GSP012YH series emergency driver uses high-temperature resistant nickel-cadmium battery as energy storage to ensure that the battery charge and discharge meets the requirements when the ambient temperature is 50 degrees. At the same time, to ensure safety, the driver has been equipped with output short circuit protection, open circuit protection, under voltage protection and other functions.

II. Product Picture



The picture is for reference only. It's subject to change without further notice.

Statement:

1. The emergency driver needs to be disconnected with the battery before transportation. During transportation, it's not allowed to be electric.
2. The emergency driver needs to be wired by a professional who has an electrician's certificate. The

connection of the input and output terminals cannot be reversed. This product cannot be powered with AC electricity before all wiring is done. The battery needs to be charged for at least 1 hour before the first emergency testing.

3. The product is sold with an LED indicator, an emergency testing button and a white control panel separately placed in a bag. It's suggested to install the LED indicator and the emergency testing button to the white control panel and fix the completed control panel to the wall with screws. Alternatively, the LED indicator and the emergency testing button can be used without being installed to the control panel.

III. Parameters

Input performance	Input voltage	100-277VAC, 50/60Hz
	Input current	≤0.06A
	Input power	≤6W
	Surge current	≤20A
	battery	Ni-Cd 14.4V 28.8WH
	Charging time of the battery	≤24H
Output performance	Driver type	Constant power
	Output current	≤500mA
	Output voltage	25-48VDC
	Output power	5W, 7W, 10W, 12W
	Tolerance of output power	±5%
	Reaction time for emergency	<0.5 sec.
	Emergency time	90 min. (in condition of 12W)
Features of AC driver	Input voltage	100-277VAC, 50/60Hz
	Output voltage	25-48VDC
	Output current	≤2A
	Output power	≤96W
Protective function	Open-circuit protection	Open circuit voltage <55V
	Short-circuit protection	Hardware circuit protection. Auto-recovery
Environment description	Operating temperature / humidity	0°C-50°C, 10%RH-80%RH
	Storage temperature / humidity	-20°C-60°C, 5%RH-85%RH
Safety compliance	Voltage withstand	I/P-O/P:3.75KVac, 5mA 60S I/P-F/G:1.5KVac, <5mA 60S O/P-F/G:1.5KVac, <5mA 60S
	Insulation resistance	I/P-O/P:500VDC>100MΩ
	Surge rating	L-N:2KV, L&N-PE:2KV
	Electromagnetic compatibility	Conform to FCC Part 15B & EN55015
	Certificate	UL, FCC, CE
Others	Dimension & weight	L*W*H: 245*44*29mm; weight: 250g

	Lifetime	5 years
Remarks	<p>1. Unless otherwise stated, the features and parameters above were typical values tested under the ambient temperature 25°C and 100% load.</p> <p>2. A driver as a component being used with a terminal device, its EMC performance is affected by the LED light fixture and the wiring, therefore, the terminal device manufacturer needs to re-evaluate the EMC of the whole device.</p>	

IV. Dimension

4.1 Dimension of the driver housing L*W*H = 245 * 44 * 29 mm

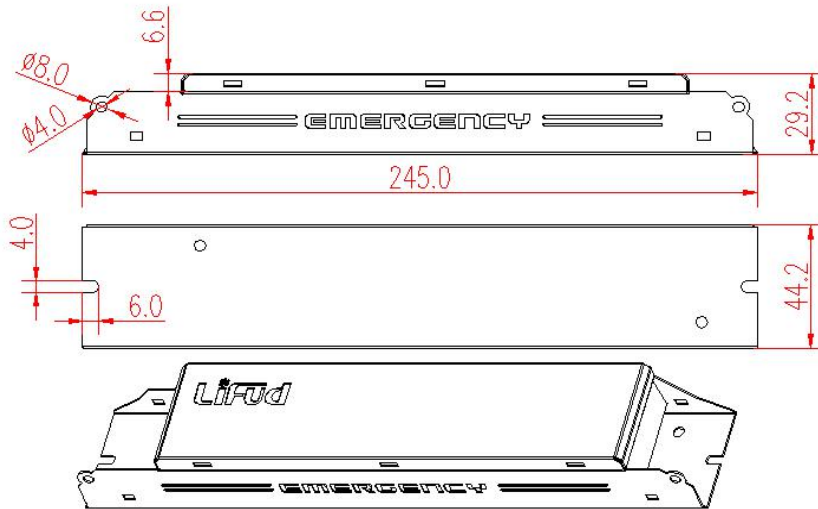

4.2 Dimension of the battery housing L*W*H = 279*46*25 mm

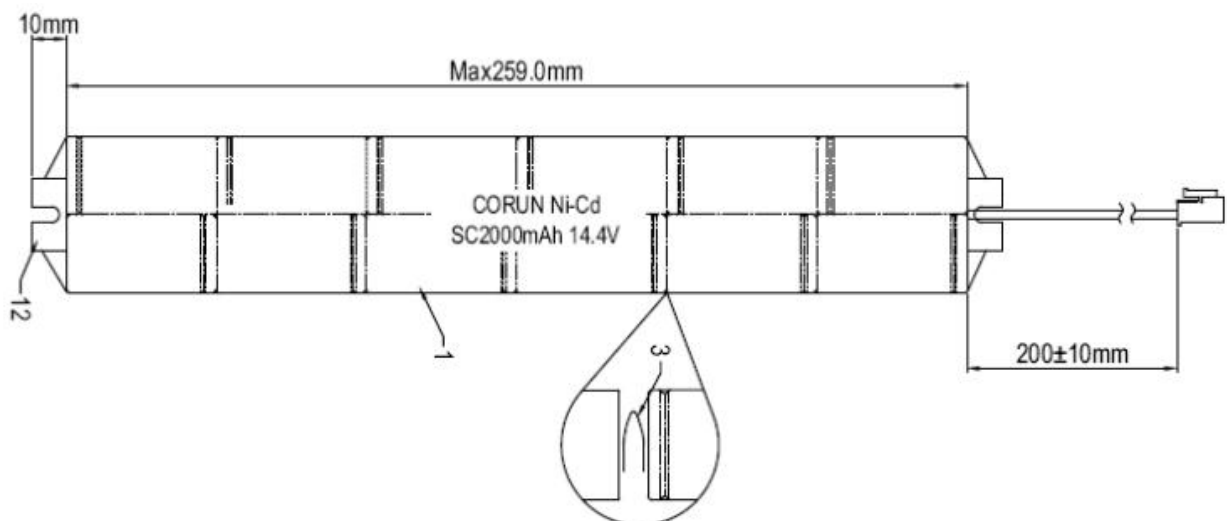

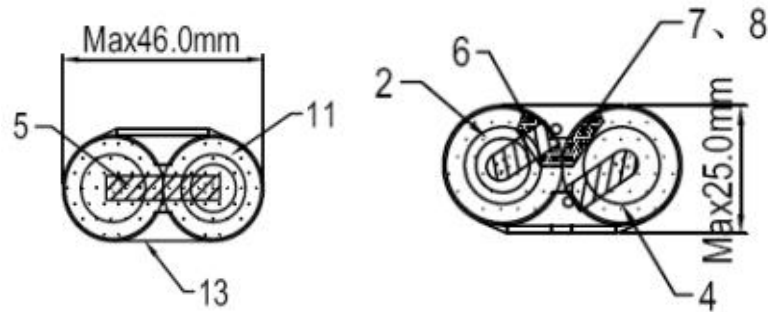

V. Wiring Diagram & Function Description

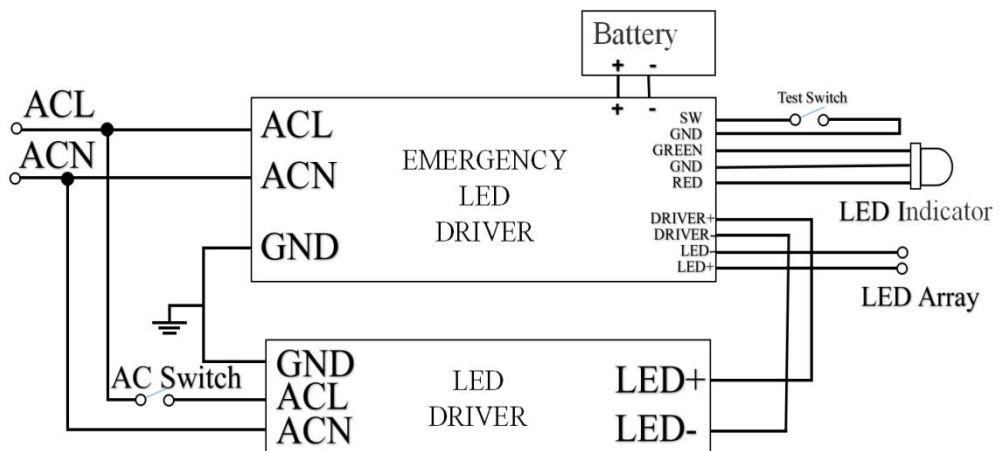

5.1 AC power supply

- 1) AC switch OFF: The battery is charging; The LED indicator light keeps red. The LED lighting is off.
- 2) AC switch ON: The battery is charging; The LED indicator light keeps red. The LED lighting is on. Supports external constant current LED driver with output DC 25-48V and less than 2A DC.
- 3) When AC switch is ON and the SW switch and GND are in short circuit, the LED indicator light shows green light and blinks, 0.5s on & 0.5s off. The LED emergency light enters the simulation emergency mode. The LED lighting is on.

5.2 AC power failure

Within 500ms, the lighting is switched to emergency lighting and powered by the battery. The LED indicator light keeps green. The LED lighting is on. When the battery has not enough quantity of electricity, the green LED indicator light continuously blinks five times, 1s on and 2s off.

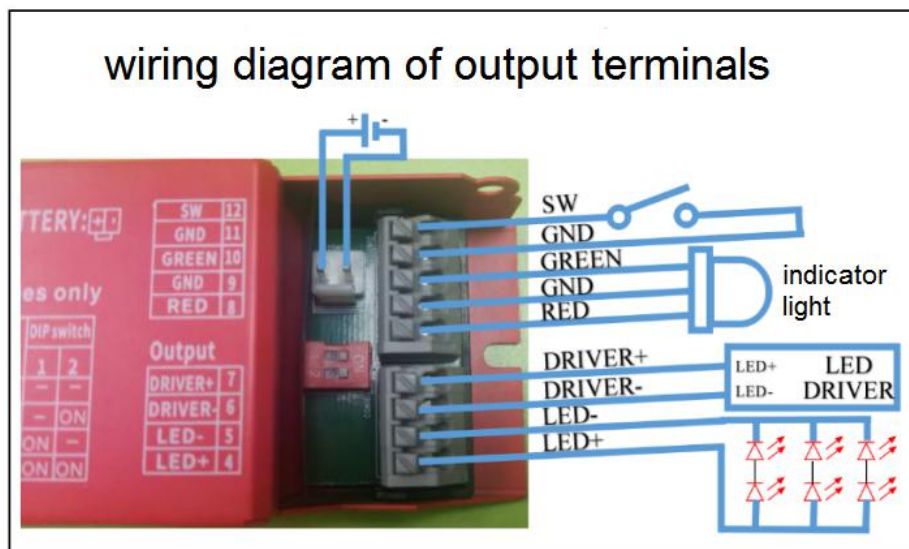
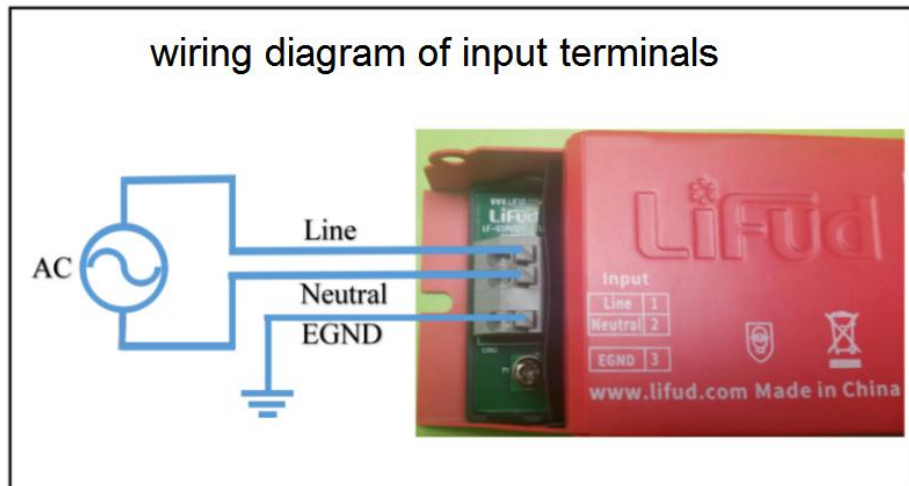

VI. State Description of the LED Indicator Light

LED indicator light state	Emergency driver state
Keeps red	The battery is not filled but normal.
Off	The battery is filled but normal.
Blinks between red and green every 0.5 sec.	The battery is almost running out of power or is damaged.
The red light blinks in a high frequency.	The battery is reversely connected or is disconnected.
Keeps green	The battery is discharging.
The green light continuously blinks five times, 1 sec. on and 2 sec. off.	The battery is running out of power.

VII. State Description of the DIP Switch

DIP switch nature	Adjustment switch of emergency power				
DIP switch state	Switch state		Output power	Output voltage range	Emergency time
	DIP1	DIP2			
	OFF	OFF	5W	25V-48V	≥210 min.
	OFF	ON	7W	25V-48V	≥150 min.
	ON	OFF	10W	25V-48V	≥100 min.
ON	ON	12W	25V-48V	≥90 min.	

Two groups of DIP switches can refer to 4 states. The output power in different states can be customized according to customers' requirements. There are 4 output power options, 5W, 7W, 10W and 12W.

Under an ambient temperature between 0°C - 50°C, the equipped battery meets the discharging requirements of emergency power of 12W and emergency time at least 90 minutes. If the emergency power is 10W, the emergency discharge time is at least 100 minutes. If the emergency power is 7W, the emergency discharge time is at least 150 minutes. If the emergency power is 5W, the emergency discharge time is at least 210 minutes.

If the ambient temperature is below 0°C or above 50°C, even though this emergency driver can work, the emergency time can not be guaranteed to meet the specified requirements. Besides, the lifetime of the battery may be reduced. In that case, Lifud does not guarantee that this product will reach the specified lifetime.

VIII. Statement of how the emergency button works

When the emergency testing SW switch and GND are in short circuit, the LED indicator light shows green light and blinks, 0.5s on & 0.5s off. The LED emergency light enters the simulation emergency mode. The LED lighting is on.

IX. Packaging

9.1 Expanded Polyethylene

Dimension: 375*275*37mm

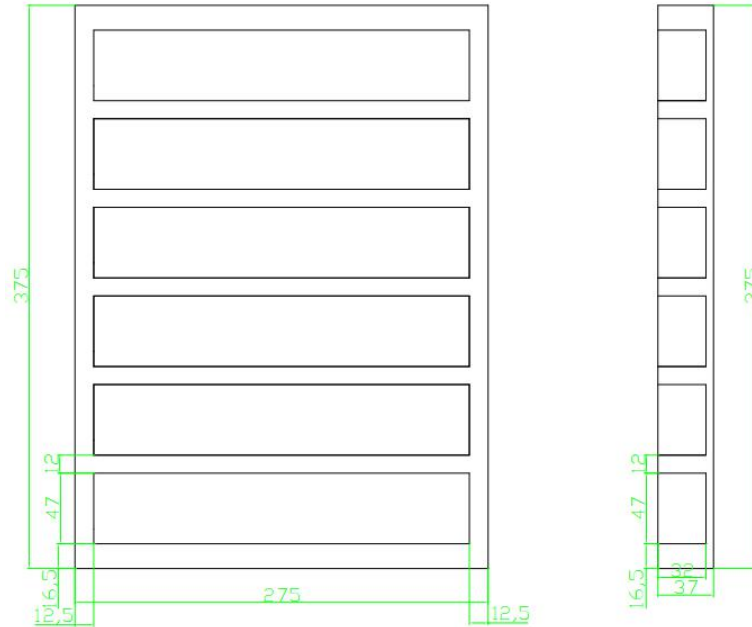

There are 6 pieces of products on each layer.

9.2 External Packaging

Carton dimension: 385*285*210mm

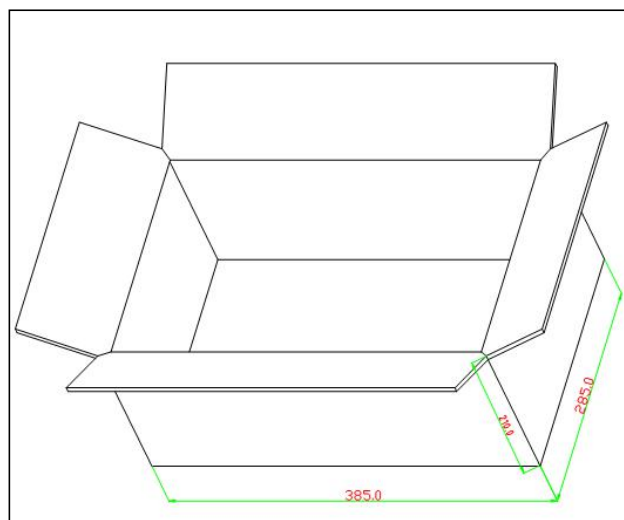

There are 5 layers in every packaging box. 30pcs of products in total.